

# Chisum Bronco XL





## DRIVE ON, DRIVE OFF CAPABILITIES

Optional Drive Off Ramp available.



## 16 LIGHTWEIGHT REMOVABLE TREADWAYS

Allows technicians access to diagnose, measure, and visually inspect underbody damage.



Machine and milled surface designed to work with all Celette\* fixtures, dedicated, universal, and the chameleon.



## **PULL TOWER**

Chisum uses OTC Time Tested Hydraulic Pumps and Rams that offers an impressive 10 tons of pulling power. Capable of performing low, down, and high pulls, along with a true 360-degree pulling radius. Additional pull towers are also available.



## **CHAIN SLOTS**

Our chain slots are strategically integrated into the main frame. Perfect for quick tie-downs. Ideal for pulling radiator supports, rear body panels, and much more.



## **GREASE FITTINGS**

Chisum uses 10 industrial grade, high-quality, brass grease fittings to ensure longevity.



### HAND HELD REMOTE CONTROL

Operate the Chisum Bronco XL effortlessly by the push of a button with our electric-hydraulic remote control.



### DUAL HYDRAULICS LIFT RAMS

Lift Capacity of 8,800 lbs. Strong enough to handle most unibody and full size pick up trucks, vans, and suvs.



### CHISUM TRUCK ANCHORING

Convenient and easy to move cart. Also to assist technicians when anchoring full frame vehicles.



## **4 POINT ANCHORING FOR UNIBODY**

At Chisum we use high quality industrial grade hardware on our clamping systems.



## **FULL FRAME ANCHORING**

Our standard anchoring system is rugged enough to add Chisum's truck anchoring systems.



## **THE NEW CHISUM WRANGLER**

Our most popular anchoring system, easy to use, and not a lot of components. By incorporating heat treated stainless steel into our steel blend, this increases the gripping power needed to securely hold the frames being used on the vehicles of today.

# SPECIFICATIONS

<b>Length</b>	16 ft
<b>Width</b>	88"
<b>Adjustable Height</b>	7.25 to 56 in.
<b>Approx. Weight (in lbs.)</b>	4910
<b>Pulling Power</b>	10 tons
<b>Lift Capacity</b>	8,800 lbs
<b>Tie Downs</b>	12
<b>Grease Fittings</b>	10
<b>Treads</b>	16
<b>Fixture / Jig Capability</b>	Designed to work with Celette* fixtures

# Chisum

**Our Standard Anchoring is Engineered and Designed to Work With our Full Frame Anchoring System**

\*Celette is a registered trademark of Celette®

**Optional Drive Off Capabilities**

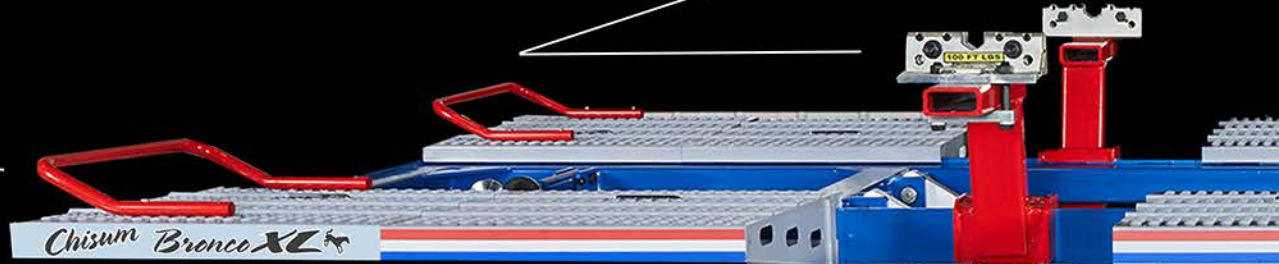

**Handheld Remote Control**



**Grease Fittings**

**Dual Hydraulic Lift Rams**

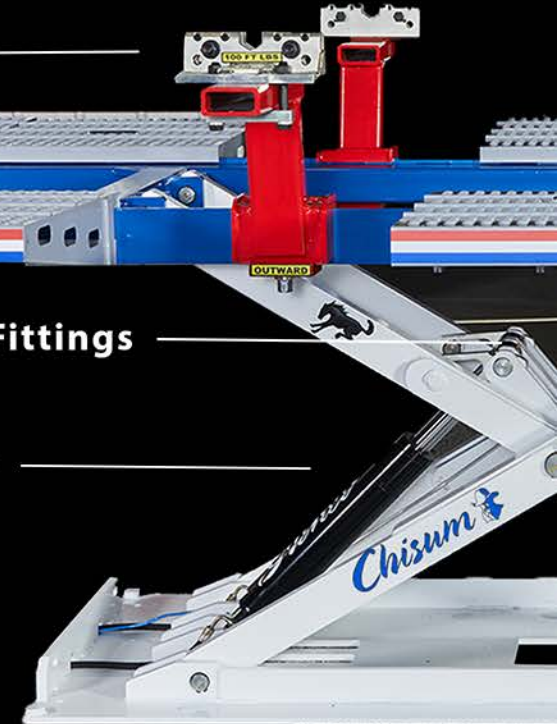

# Bronco XL

**4 Point Anchoring with  
Hardened Industrial Special  
Bolts**

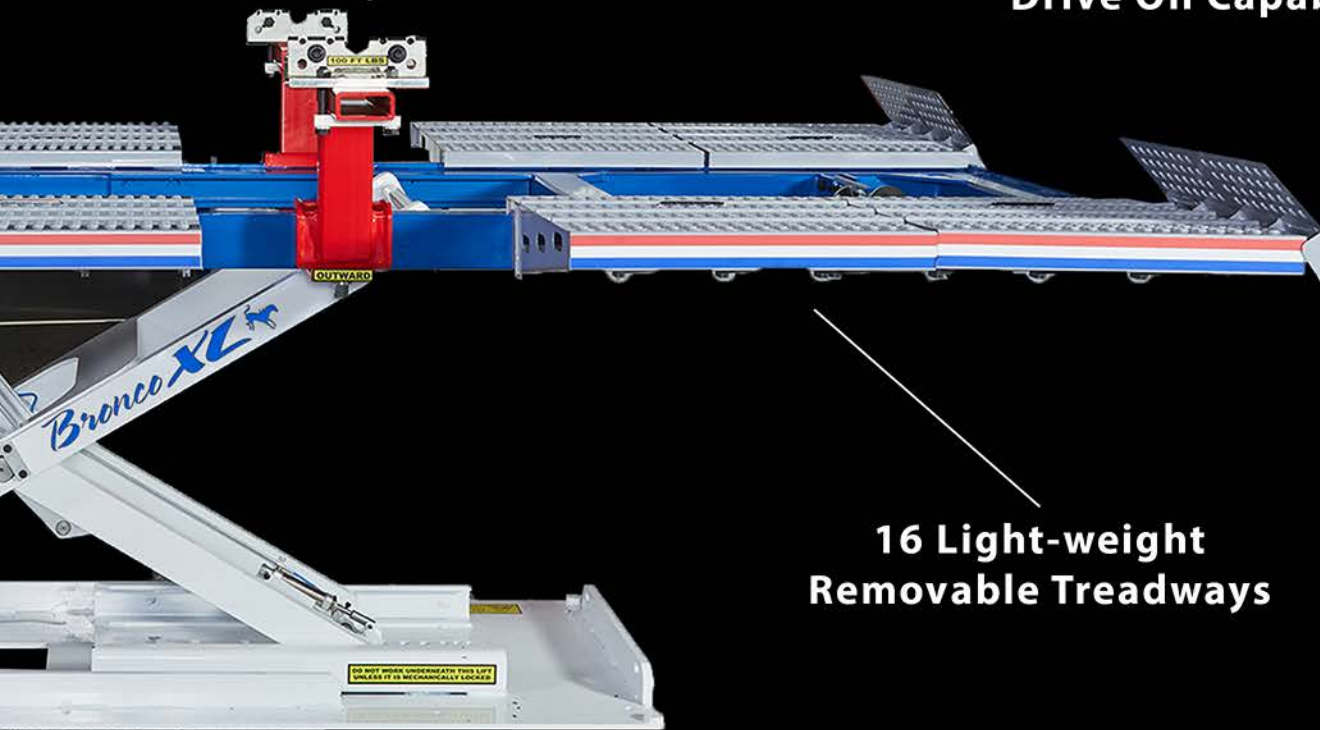

**Drive On Capabilities**

**16 Light-weight  
Removable Treadways**

**OTC Time Tested  
Hydraulic**





# Chisum Bronco XL

## Not Your Average Frame Machine

Back in 1969, Lavell Chisum crafted his very first machine. Fast forward over 55 years later, we're thrilled to introduce the Chisum Bronco XL. Built on that legendary Chisum quality, this machine is a game-changer in the world of collision repair. Whether it's uni-body or full frame vehicles, Chisum's got you covered. Perfect for every vehicle going through the shop. Ideal for writing an estimate, disassembling a vehicle, or doing a supplement. Whether you're making quick pull, changing a bumper, or handling a big repair on a unibody or full frame, the new Chisum Bronco XL is perfect.

Celette is a registered trademark of Celette®  
Chisum is a registered trademark.



Watch this 80  
second video

[www.lombardequipment.com](http://www.lombardequipment.com) • 1-800-422-7855 •      